

SHORT PLAT

LOCATED IN A PORTION OF FARM UNIT 315, BLOCK 16, COLUMBIA BASIN PROJECT,
LOCATED IN A PORTION OF THE SE, SW AND NW 1/4 OF THE SE 1/4 OF SECTION
22 AND IN THE SW, SE AND NE 1/4 OF THE SW 1/4 OF SECTION 22

T 11 N, R 29 E, W.M.

FRANKLIN COUNTY, WASHINGTON

JOB NUMBER: 25-389

OCTOBER 27, 2025

UNITED STATES DEPARTMENT OF THE INTERIOR BUREAU OF RECLAMATION

BUREAU OF RECLAMATION CONCURRENCE FOR THIS PLAT IS LIMITED TO THE EXTENT OF THE PLAT'S COMPLIANCE WITH THE REQUIREMENTS OF RCW 56.17.310.

DRAIN CONSTRUCTION: RISING GROUND WATER TABLES ARE COMMON IN IRRIGATION PROJECTS. FEDERAL DRAIN CONSTRUCTION FUNDS ARE NOT AVAILABLE FOR DRAINING OF SUBDIVISIONS AND OTHER AREAS NOT IN A COMMERCIAL AGRICULTURE LAND USE, UNLESS DRAINAGE IS INCIDENTAL TO THE REQUIRED DRAINAGE OF ADJACENT AGRICULTURAL LAND AND MEETS FEDERAL TECHNICAL AND ECONOMIC FEASIBILITY REQUIREMENTS.

THIS LAND IS INCLUDED WITHIN THE SOUTH COLUMBIA BASIN IRRIGATION DISTRICT AND IS SUBJECT TO THE LAWS OF THE UNITED STATES AND THE STATE OF WASHINGTON RELATIVE TO THE COLUMBIA BASIN PROJECT AND IS LIABLE FOR FURTHER ASSESSMENTS, IF ANY, LEVIED BY SAID DISTRICT. IT IS ALSO UNDERSTOOD AND AGREED THAT WHEN THIS PLAT IS SERVED BY COUNTY ROADS, IRRIGABLE LAND WITHIN THE ROAD RIGHT-OF-WAY OR ISOLATED BY SAND DEDICATION WILL NOT BECOME A CHARGE ASSESSABLE TO FRANKLIN COUNTY AND PAYABLE TO THE SOUTH COLUMBIA BASIN IRRIGATION DISTRICT FOR CONSTRUCTION, OPERATION AND MAINTENANCE OF THE PROJECT.

SOUTH COLUMBIA BASIN IRRIGATION DISTRICT

IRRIGATION APPROVAL:

WATER SUPPLY CONCURRENCE BY THE BUREAU OF RECLAMATION FOR THIS PLAT DOES NOT ASSURE THE AVAILABILITY OF A WATER SUPPLY, NOR DOES IT BIND THE UNITED STATES TO ISSUE A PERMANENT RIGHT FOR A FEDERAL WATER SUPPLY. A WATER SUPPLY PROJECT WATER TO THIS LAND IS ASSURED ONLY UPON FULL COMPLIANCE WITH COROLLARY FEDERAL AND STATE LEGISLATION.

BUREAU OF RECLAMATION

IRRIGATION AND OWNER'S CERTIFICATE

THE PROPERTY DESCRIBED HEREIN IS LOCATED WHOLLY OR IN PART WITHIN THE BOUNDARIES OF THE SOUTH COLUMBIA BASIN IRRIGATION DISTRICT ("DISTRICT"). THE DISTRICT HEREBY CERTIFIES THAT THE IRRIGATION EASEMENTS AND RIGHTS OF WAY SHOWN ON THE PLAT ARE ADEQUATE TO SERVE ALL LOTS LOCATED WITHIN THE PLAT AND OTHER ADJACENT LANDS WHICH ARE ENTITLED TO DISTRICT WATER. A SEPARATE WRITTEN AGREEMENT FOR COMPLETED IRRIGATION FACILITIES ____ HAS BEEN APPROVED; OR ____ WILL NOT BE REQUIRED. (CHECK ONE)

THE OWNERS ACKNOWLEDGE THE USE AND EXISTENCE OF IRRIGATION WATER AND DELIVERY SYSTEMS MUST COMPLY WITH ALL DISTRICT RULES AND REGULATIONS AND MAY CAUSE DAMAGE OR BE A HAZARD TO PROPERTY AND PERSONS. THE OWNER ASSUMES ALL RISK ASSOCIATED WITH THE USE OF THE DELIVERY OF IRRIGATION WATER AND WAIVES THE DISTRICT HARMLESS AND WAIVES ON BEHALF OF THEMSELVES AND THEIR SUCCESSORS IN INTERESTS AND CLAIMS FOR DAMAGES OF ANY KIND AGAINST THE DISTRICT WHICH MAY BE CAUSED BY THE CONSTRUCTION, OPERATION, OR MAINTENANCE OF THE IRRIGATION FACILITIES, OR FROM THE DELIVERY, LEAKAGE, OR SEEPAGE OF WATER.

SOUTH COLUMBIA BASIN IRRIGATION DISTRICT

LEONARD J. VAN RYN

ANTHONY R. VAN RYN

OWNER'S CERTIFICATE

WE, THE UNDERSIGNED, HEREBY CERTIFY THAT WE ARE THE OWNERS OF THE TRACT OF LAND DESCRIBED HEREON, THAT WE HAVE CAUSED SAID LAND TO BE SURVEYED AND SHORT PLATED INTO LOTS AS SHOWN HEREON, AND DEDICATED TO THE PUBLIC ALL EASEMENTS AND STREET RIGHT-OF-WAYS SHOWN HEREON.

LEONARD J. VAN RYN

ANTHONY R. VAN RYN

ACKNOWLEDGMENT:

STATE OF WASHINGTON
COUNTY OF FRANKLIN

I, CERTIFY THAT I KNOW OR HAVE SATISFACTORY EVIDENCE THAT _____ IS THE PERSON WHO APPEARED BEFORE ME, AND SAID PERSON ACKNOWLEDGED THAT HE SIGNED THIS INSTRUMENT AND ON OATH STATED THAT HE IS AUTHORIZED TO EXECUTE THIS INSTRUMENT AND ACKNOWLEDGED IT AS THE FREE AND VOLUNTARY ACT OF SUCH PARTY FOR THE USES AND PURPOSES MENTIONED ON THIS INSTRUMENT.

NOTARY PUBLIC

MY APPOINTMENT EXPIRES _____

RESIDING _____

ACKNOWLEDGMENT:

STATE OF WASHINGTON
COUNTY OF FRANKLIN

I, CERTIFY THAT I KNOW OR HAVE SATISFACTORY EVIDENCE THAT _____ IS THE PERSON WHO APPEARED BEFORE ME, AND SAID PERSON ACKNOWLEDGED THAT HE SIGNED THIS INSTRUMENT AND ON OATH STATED THAT HE IS AUTHORIZED TO EXECUTE THIS INSTRUMENT AND ACKNOWLEDGED IT AS THE FREE AND VOLUNTARY ACT OF SUCH PARTY FOR THE USES AND PURPOSES MENTIONED ON THIS INSTRUMENT.

NOTARY PUBLIC

MY APPOINTMENT EXPIRES _____

RESIDING _____

SURVEYOR'S CERTIFICATE:

I, KEVIN L. BETHLE, A REGISTERED LAND SURVEYOR, HEREBY CERTIFY THAT THE SHORT PLAT AS SHOWN IS BASED UPON ACTUAL FIELD SURVEY OF THE LAND DESCRIBED AND THAT ALL ANGLES, DISTANCES, AND COURSES ARE HEREOF CORRECTLY SHOWN AND THAT THE LOT CORNERS HAVE BEEN STAKED ON THE GROUND AS SHOWN ON THE MAP.

KEVIN L. BETHLE, PROFESSIONAL LAND SURVEYOR DATE: 10-27-2025
PLS NO. 38490

DEED REFERENCE:

GRANTOR: VAN RYN INVESTMENTS
GRANTEE: LORRETTA J. VAN RYN, TRUSTEE
AF NO. 1865286
DATE: 07-25-2017

SURVEY REFERENCES:

- 1) USBR COLUMBIA BASIN PROJECT RETRACEMENT MAP, SOUTH HALF OF T 11 N, R 29 E, SERIAL NO. A-5303, DATED 12-29-39
- 2) CHRISTENSON SURVEY, VOLUME 2, PAGE 482
- 3) BAUMAN SHORT PLAT 2015-13, VOLUME 2, PAGE 27
- 4) HACKWITH SHORT PLAT 80-4, AF NO. 399199
- 5) GOLADAY SURVEY, VOLUME 1, PAGE 986
- 6) STRATTON SURVEY, VOLUME 1, PAGE 437
- 7) CHRISTENSON SURVEY, VOLUME 2, PAGE 77
- 8) COLUMBIA BASIN SOUTH IRRIGATION ZONE BLOCK 16, MAP NUMBER 50, REVISION DATE 1-15-76, SERIAL NUMBER 222-116-32552-50
- 9) COLUMBIA BASIN SOUTH IRRIGATION ZONE BLOCK 16, MAP NUMBER 48, REVISION DATE 12-29-89, SERIAL NUMBER 222-116-32552-48
- 10) COLUMBIA BASIN SOUTH IRRIGATION ZONE BLOCK 16, MAP NUMBER 49, REVISION DATE 1-15-76, SERIAL NUMBER 222-116-32552-49
- 11) CHRISTENSON SHORT PLAT 2001-15, VOLUME 1, PAGE 538
- 12) STRATTON SURVEY, VOLUME 1, PAGE 692
- 13) HACKWITH SHORT PLAT 98-8, VOLUME 1, PAGE 459
- 14) STANLEY SHORT PLAT 84-7, VOLUME 1, PAGE 220

TREASURER'S CERTIFICATE

I HEREBY CERTIFY THAT THE TAXES ON THE LAND DESCRIBED HEREON HAVE BEEN PAID TO AND INCLUDING THE YEAR _____ A.D.

FRANKLIN COUNTY TREASURER

DATE _____

NOTES

- 1) APPROACH PERMITS ARE REQUIRED FOR ANY NEW APPROACHES ONTO FRANKLIN COUNTY ROADS.
- 2) THE OWNERS NAMED HEREON ARE RESPONSIBLE FOR PROVIDING AND BACKFILL FOR THE BBEC CONDUIT PRIMARY VAULTS, SECONDARY JUNCTION BOXES, AND BACKFILL FOR THE BBEC PRIMARY AND SECONDARY DISTRIBUTION SYSTEM IN ACCORDANCE WITH THE BBEC SPECIFICATIONS. SAID OWNERS WILL MAKE FULL ADVANCE PAYMENT OF LINE EXTENSION FEES AND WILL PROVIDE ALL NECESSARY UTILITY EASEMENTS PRIOR TO BBEC CONSTRUCTION AND/OR CONNECTION OF ELECTRICAL SERVICE TO THE PLAT.
- 3) LAND WITHIN THIS SHORT SUBDIVISION SHALL NOT BE FURTHER SUBDIVIDED FOR A PERIOD OF FIVE (5) YEARS UNLESS A FINAL PLAT IS FILED PURSUANT TO FRANKLIN COUNTY CODE CHAPTER 16.20, FRANKLIN COUNTY CODE CHAPTER 16.24 AND RCW 58.17.
- 4) INFORMATION ON THIS PLAT PERTAINING TO IRRIGATION BLOCKS, FARM UNITS, BUREAU OF RECLAMATION FACILITIES AND THEIR ASSOCIATED RIGHTS-OF-WAY MAY NOT AGREE WITH THE CORRESPONDING FARM UNIT MAPS. PLEASE REFER TO THE APPROPRIATE FARM UNIT MAP FOR INFORMATION CONCERNING THESE FEATURES. (ONLY APPLIES TO USBR MAPS)
- 5) ADDRESSES WILL BE DETERMINED BY THE COUNTY WHEN THE BUILDING PERMITS ARE ISSUED.
- 6) ADDRESS NUMBERS [NOTED IN BRACKETS]
- 6) PARK DEDICATION FEE SHALL APPLY TO LOT 2 OF THIS SHORT PLAT. THIS FEE SHALL BE PAID PRIOR TO BUILDING PERMIT ISSUANCE OF ANY NEW DWELLING UNIT ON LOT 2.
- 7) BENTON FRANKLIN HEALTH DISTRICT REQUIRES THAT ALL SEPTIC AND ON-SITE DRAIN FIELDS BE LOCATED NO CLOSER THAN 100 FEET FROM ANY SURFACE WATER.
- 8) THE FOLLOWING SEPARATION STANDARDS SHALL BE REQUIRED FOR ALL NEW STRUCTURES ON EACH LOT OR PARCEL, UNLESS THERE IS AN OPERATIONAL FIRE HYDRANT, MEETING FIRE FLOW REQUIREMENTS, LOCATED WITHIN 500 FEET OF LOT OR PARCEL. THE FOLLOWING SETBACKS SHALL APPLY:
FRONT: TWENTY FIVE (25) FEET
REAR: TWENTY FIVE (25) FEET
SIDE: TWENTY (20) FEET
- 9) BETWEEN STRUCTURES: FIFTEEN (15) FEET. THE STRUCTURE SEPARATION MAY BE REDUCED WITH THE CONSTRUCTION OF AN APPROVED ONE-HOUR INTERVENING FIRE WALL.
- 10) DURING CONSTRUCTION ON EACH PROPERTY, ALL CONSTRUCTION DEBRIS SHALL BE MAINTAINED ON-SITE AND PROPERLY DISPOSED OF. DUST CONTROL MEASURES INCLUDING AN ADEQUATE WATER SUPPLY SHALL BE PROVIDED.
- 11) LOT 1 AS SHOWN ON THIS SHORT PLAT WAS CREATED PURSUANT TO THE INNOVATIVE AGRICULTURAL SHORT PLAT STANDARDS OF FRANKLIN COUNTY CODE 17.10.050(F)(1). LOT 1 IS LESS THAN TWENTY (20) ACRES IN SIZE AND THERE SHALL BE A MINIMUM OF FORTY (40) ACRES SET ASIDE FOR THIS LOT IN THE MAIN FARM PARCEL, LOT 2, AS STATED IN FRANKLIN COUNTY CODE CHAPTER 16.32.10(C).
- 12) FRANKLIN COUNTY IS NOT RESPONSIBLE FOR THE MAINTENANCE OF PRIVATE EASEMENTS.
- 13) PRIVATE ACCESS ROAD EASEMENTS SHALL BE CONSTRUCTED AS FIRE APPARATUS ACCESS ROADS AS DESCRIBED IN THE FRANKLIN COUNTY DESIGN STANDARDS.
- 14) THE UTILITY EASEMENTS SHOWN HEREON ARE HEREBY GRANTED FOR THE USE, ACCESS, AND MAINTENANCE BY THE SHORT PLATED PROPERTY'S CURRENT UTILITY PROVIDER, SAID UTILITY EASEMENTS ARE FOR THE USE, ACCESS AND MAINTENANCE OF ELECTRIC POWER, TELEPHONE, CABLE, AND OTHER DEFINED UTILITIES, TO AND OR THROUGH SAID TRACT.
- 15) APPROVAL OF THIS LAND DIVISION DOES NOT GUARANTEE THE APPROVAL OR ISSUANCE OF FUTURE BUILDING PERMITS.

APPROVALS

THE UTILITY EASEMENTS SHOWN HEREON ARE HEREBY APPROVED FOR THE BIG BEND ELECTRIC COOPERATIVE, INC.

BIG BEND ELECTRIC COOPERATIVE, INC. DATE _____

THE ANNEXED SHORT PLAT IS HEREBY APPROVED BY AND FOR THE COUNTY OF FRANKLIN, STATE OF WASHINGTON.

FRANKLIN CO. DIRECTOR OF PLANNING AND BUILDING DATE _____

THE ANNEXED SHORT PLAT IS HEREBY APPROVED BY AND FOR THE COUNTY OF FRANKLIN, STATE OF WASHINGTON.

FRANKLIN CO. ENGINEER DATE _____

THE ANNEXED SHORT PLAT IS HEREBY APPROVED BY AND FOR THE COUNTY OF FRANKLIN, STATE OF WASHINGTON.

BENTON-FRANKLIN COUNTY HEALTH DEPARTMENT DATE _____

AUDITOR'S CERTIFICATE

FILED FOR RECORD THIS _____ DAY OF _____, 202 AT _____ M,
IN VOLUME _____ OF SHORT PLATS AT PAGE _____ AT THE REQUEST OF
SCHRADER REAL ESTATE AUCTIONS.

FRANKLIN COUNTY AUDITOR AF NO. _____

SCALE: NA

JOB NO. 25-389

DATE: 10-27-2025

CALC BY: KLB

DRAWN BY: KLB

CHECKED BY: _____

SHEET 1 OF 4

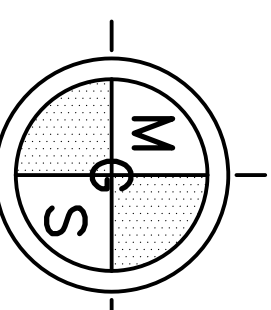

MGS
PASCO, INC.
809 S AUBURN ST
KENNEWICK, WA 99336
509-491-1071

SURVEY REFERENCES:

- 1) USBR COLUMBIA BASIN PROJECT RETRACEMENT MAP, SOUTH HALF OF T 11 N, R 29 E, SERIAL NO. A-5303, DATED 12-29-39
- 2) CHRISTENSON SURVEY, VOLUME 2, PAGE 462
- 3) BAALMAN SHORT PLAT 2015-15, VOLUME 2, PAGE 27
- 4) HACKWITH SHORT PLAT 80-4, AF NO. 399199
- 5) GOLLADAY SURVEY, VOLUME 1, PAGE 986
- 6) STRATTON SURVEY, VOLUME 1, PAGE 437
- 7) CHRISTENSON SURVEY, VOLUME 2, PAGE 77
- 8) COLUMBIA BASIN SOUTH IRRIGATION ZONE BLOCK 16, MAP NUMBER 50, REVISION DATE 1-15-76, SERIAL NUMBER 222-116-32552-50
- 9) COLUMBIA BASIN SOUTH IRRIGATION ZONE BLOCK 16, MAP NUMBER 48, REVISION DATE 12-29-89, SERIAL NUMBER 222-116-32552-48
- 10) COLUMBIA BASIN SOUTH IRRIGATION ZONE BLOCK 16, MAP NUMBER 49, REVISION DATE 1-15-76, SERIAL NUMBER 222-116-32552-49
- 11) CHRISTENSON SURVEY, VOLUME 1, PAGE 692
- 12) STRATTON SURVEY, VOLUME 1, PAGE 538
- 13) HACKWITH SHORT PLAT 98-8, VOLUME 1, PAGE 459
- 14) STANLEY SHORT PLAT 84-7, VOLUME 1, PAGE 220

SHORT PLAT

LOCATED IN A PORTION OF FARM UNIT 315, BLOCK 16, COLUMBIA BASIN PROJECT, LOCATED IN A PORTION OF THE SE, SW AND NW 1/4 OF THE SE 1/4 OF SECTION 22 AND IN THE SW, SE AND NE 1/4 OF THE SW 1/4 OF SECTION 22

T 11 N, R 29 E, W.M.
FRANKLIN COUNTY, WASHINGTON

JOB NUMBER: 25-389

OCTOBER 27, 2025

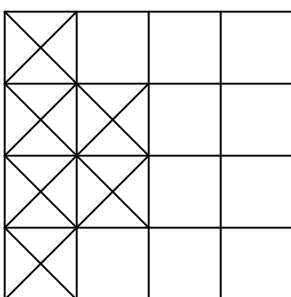

SECTION INDEX
SECTION 22
T 11 N, R 29 E

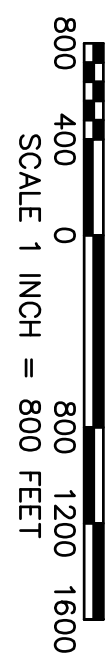

SCALE 1 INCH = 800 FEET

BASIS OF BEARING:
WASHINGTON SOUTH ZONE STATE PLANE COORDINATE SYSTEM, NAD83/2011, PER OPUS SOLUTION AT SOUTH QUARTER CORNER OF SECTION 22 SCALE FACTOR 0.99988113 APPLIED AT MONUMENT FOUND AT SOUTH QUARTER CORNER OF SECTION 22. DISTANCES SHOWN ARE GROUND DISTANCES.

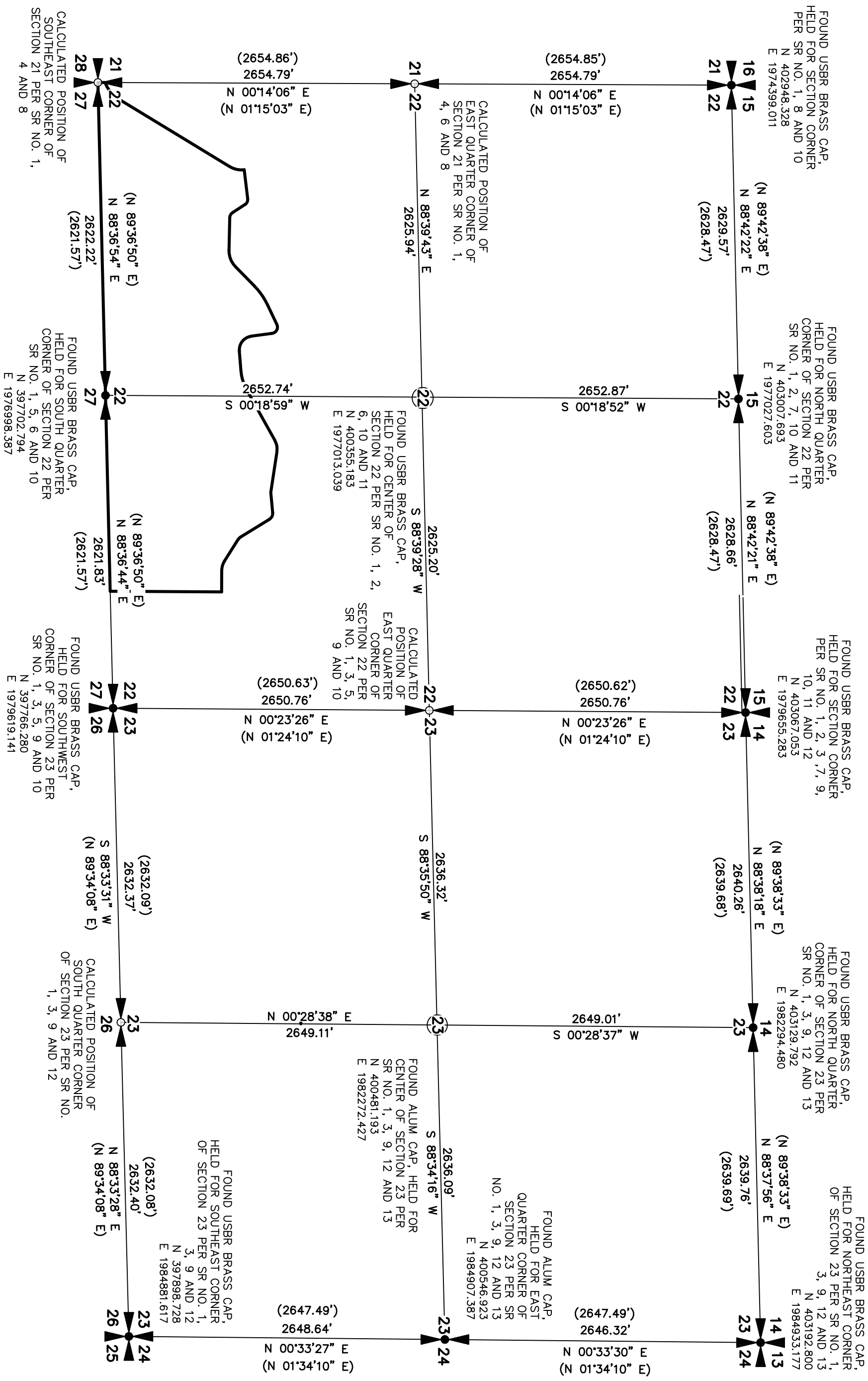

LEGEND:

- INDICATES FOUND MONUMENT AS NOTED
- INDICATES CALCULATED POSITION NOTHING FOUND OR SET.
- INDICATES PERIMETER BOUNDARY LINE
- INDICATES INTERIOR AND ADJUSTED BOUNDARY LINE
- INDICATES SECTION LINE
- INDICATES LOT LINES TO BE ADJUSTED
- INDICATES GRID NORTHING AND EASTING
- N xxxxxxxxxx
E xxxxxxxxxx
(xxxxxx) INDICATES RECORD DATA PER SR NO. 1

DEED REFERENCE:

GRANTOR: VAN RYN INVESTMENTS
GRANTEE: LORETTA J. VAN RYN, TRUSTEE
AF NO. 1865286
DATE: 07-25-2017

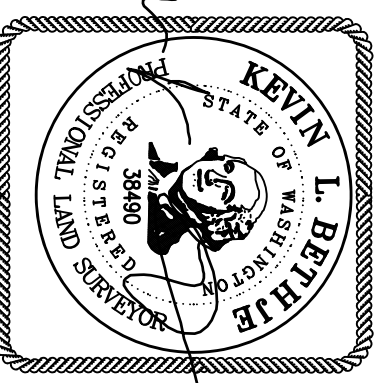

10-27-2025

MGS PASCO, INC. MAKES NO WARRANTIES AS TO MATTERS OF UNWRITTEN TITLE SUCH AS ADVERSE POSSESSION, ACQUIESCENCE, ESTOPPEL, ETC.
THIS SURVEY WAS PERFORMED BY TRIMBLE GNSS R12 OR R10 RTK AND TRIMBLE S6 TOTAL STATION. ACCURACY OF MEASUREMENTS MET THE MINIMUM STANDARDS FOR SURVEYS AS DESIGNATED IN WAC 332-130. ALL CORNERS NOTED AS FOUND WERE VISITED IN SEPTEMBER 2025

SCALE: 1"=800'
JOB NO. 25-389
DATE: 10-27-2025
CALC BY: KLB
DRAWN BY: KLB
CHECKED BY: _____
SHEET 2 OF 4

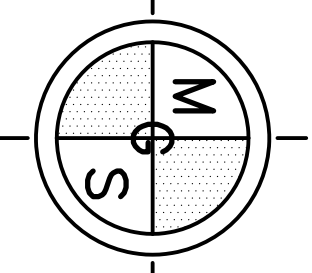

MGS
PASCO, INC.
809 S AUBURN ST
KENNEWICK, WA 99336
509-491-1071

BASIS OF BEARING:
 WASHINGTON SOUTH ZONE STATE PLANE COORDINATE
 SYSTEM, NAD83/2011, PER OPUS SOLUTION AT SOUTH
 QUARTER CORNER OF SECTION 22 SCALE FACTOR
 0.99988113 APPLIED AT MONUMENT FOUND AT SOUTH
 QUARTER CORNER OF SECTION 22. DISTANCES SHOWN ARE
 GROUND DISTANCES.

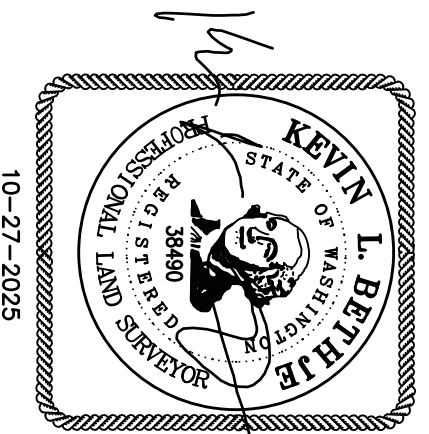

- LEGEND:**
- INDICATES FOUND MONUMENT AS NOTED
 - INDICATES 5/8" IRON ROD WITH "BETHJE 38490" PLASTIC CAP SET.
 - INDICATES CALCULATED POSITION NOTHING FOUND OR SET.
 - INDICATES PERIMETER BOUNDARY LINE
 - INDICATES INTERIOR LOT LINE
 - INDICATES SECTION LINE
 - INDICATES EASEMENT LINE AS SHOWN
 - INDICATES ROAD RIGHT-OF-WAY
 - [XXXXXX] INDICATES RECORD DATA PER SR NO. 10

SHORT PLAT

LOCATED IN A PORTION OF FARM UNIT 315, BLOCK
 16, COLUMBIA BASIN PROJECT, LOCATED IN A
 PORTION OF THE SE, SW AND NW 1/4 OF THE SE
 1/4 OF SECTION 22 AND IN THE SW, SE AND NE
 1/4 OF THE SW 1/4 OF SECTION 22
 T 11 N, R 29 E, W.M.
 FRANKLIN COUNTY, WASHINGTON
 JOB NUMBER: 25-389
 OCTOBER 27, 2025

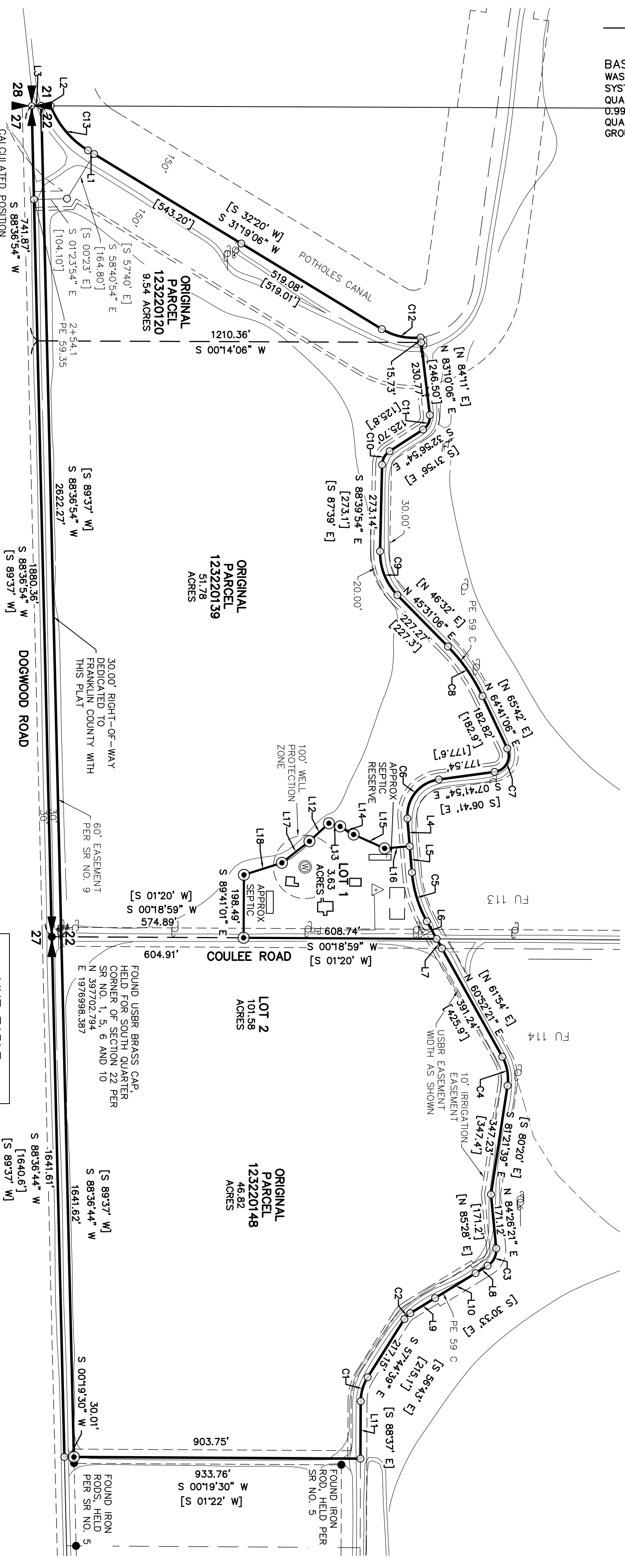

SURVEY REFERENCES:

- 1) USBR COLUMBIA BASIN PROJECT RETRACEMENT MAP, SOUTH HALF OF T 11 N, R 29 E, SERIAL NO. A-5303, DATED 12-29-89
- 2) CHRISTENSON SURVEY, VOLUME 2, PAGE 482
- 3) BALAMAN SHORT PLAT 2015-15, VOLUME 2, PAGE 27
- 4) HALLAM SHORT PLAT 80-4, AF NO. 389199
- 5) GOLLADAY SURVEY, VOLUME 1, PAGE 986
- 6) STRATTON SURVEY, VOLUME 1, PAGE 437
- 7) CHRISTENSON SURVEY, VOLUME 2, PAGE 77
- 8) COLUMBIA BASIN SOUTH IRRIGATION ZONE BLOCK 16, MAP NUMBER 50, REVISION DATE 1-15-76, SERIAL NUMBER 222-116-32552-50
- 9) COLUMBIA BASIN SOUTH IRRIGATION ZONE BLOCK 16, MAP NUMBER 48, REVISION DATE 12-29-89, SERIAL NUMBER 222-116-32552-48
- 10) COLUMBIA BASIN SOUTH IRRIGATION ZONE BLOCK 16, MAP NUMBER 49, REVISION DATE 1-15-76, SERIAL NUMBER 222-116-32552-49
- 11) CHRISTENSON SURVEY, VOLUME 1, PAGE 538
- 12) STRATTON SURVEY, VOLUME 1, PAGE 692
- 13) HACKWORTH SHORT PLAT 98-8, VOLUME 1, PAGE 459
- 14) STANLEY SHORT PLAT 84-7, VOLUME 1, PAGE 220

CURVE	RADIUS	DELTA	ARC DIST.	CHORD BEARING	CHORD DIST.
C1	143.13'	3202.23°	80.04'	S 73°45'50" E	79.00'
C2	57.27'	2610.00°	26.15'	S 44°39'39" E	25.93'
C3	57.27'	63°59'00"	63.95'	N 63°34'09" W	60.68'
C4	143.13'	37°46'00"	94.34'	S 79°45'21" W	92.65'
C5	382.00'	2421.44°	162.43'	N 73°03'14" E	161.21'
C6	114.60'	87°04'00"	174.15'	S 51°13'54" E	157.87'
C7	52.10'	107°37'00"	97.86'	N 61°30'24" W	84.09'
C8	573.00'	1910.00°	191.68'	S 55°06'06" W	190.79'
C9	191.00'	45°49'00"	152.73'	N 68°25'36" E	148.70'
C10	52.10'	55°43'00"	50.66'	S 60°48'24" E	48.69'
C11	47.80'	63°53'00"	53.30'	N 64°53'24" W	50.58'
C12	191.00'	3809.44°	127.22'	N 121°4'14" E	124.88'
C13	286.50'	3718.47°	186.58'	N 49°58'29" E	183.30'

LINE	BEARING	DISTANCE
L1	S 31°19'06" W	22.60'
L2	S 001°4'06" W	29.67'
L3	S 001°4'06" W	30.01'
L4	N 85°14'06" E	88.02'
L5	N 85°14'06" E	82.77'
L6	N 60°52'21" E	63.35'
L7	N 60°52'21" E	34.45'
L8	S 31°34'39" E	44.84'
L9	S 31°34'39" E	91.70'
L10	S 31°34'39" E	150.00'
L11	N 89°47'02" W	181.00'
L12	N 42°42'57" W	83.69'
L13	N 15°38'54" E	36.80'
L14	N 30°59'43" E	49.54'
L15	N 24°11'43" E	107.04'
L16	N 04°45'54" W	79.59'
L17	N 38°05'13" W	110.28'
L18	N 17°37'46" W	125.71'

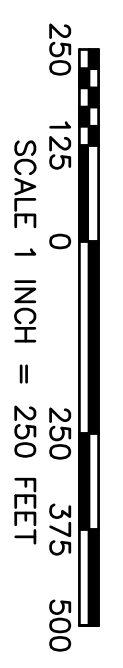

SCALE: 1"=250'
 JOB NO. 25-389
 DATE: 10-27-2025
 CALC BY: KLB
 DRAWN BY: KLB
 CHECKED BY: _____
 SHEET 3 OF 4

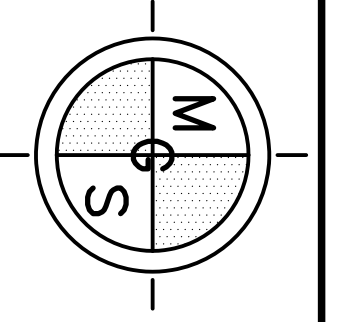

MGS
 PASCO, INC.
 809 S AUBURN ST
 KENNEWICK, WA 99336
 509-491-1071

